

Modelling to evaluate the water resource implications of planned infrastructure development in the Lake Tana sub-basin, Ethiopia

Tadesse Alemayehu^{*}, Matthew McCartney and Seifu Kebede

* Corresponding author address

Phone: +251-911750425

E-mail: tade.alex@gmail.com

P.O.Box: 20763,

Addis Ababa,

Ethiopia

Abstract

Lake Tana is important for domestic water supply, hydropower, fisheries, grazing and water for livestock, as well as reeds for boat construction. It is also important for water transport and as a tourist destination. Currently, the water resources of the catchment are largely untapped. However, water resource development is being encouraged to stimulate economic growth and reduce poverty. In this study, the Water Evaluation And Planning (WEAP) model was used to determine the water availability for different irrigation and hydropower schemes proposed. Three development scenarios were simulated and the likely impact of future water resource development on lake water levels was assessed. For each scenario, the model was used to simulate water demand in three sectors (i.e. irrigation, hydropower and downstream environmental flows) over a 36-year period of varying flow and rainfall. The simulation results revealed that if all the planned development occurs on average 2,198 GWh⁻¹ y⁻¹ power could be generated and 677 Mm³ y⁻¹ of water supplied to irrigation schemes. However, the mean annual water level of the lake would be lowered by 0.44 meters with a consequent decrease in the average surface area of the lake of 30 km². As well as adverse ecological impacts this would have significant implications for shipping and the livelihoods of many local people.

Key words: Ethiopia, Lake Tana, water level, lake surface area, water resources development, modelling, and water demand

Introduction

Water resources development, in the form of irrigation schemes and hydropower, is widely advocated as a major contributor to economic growth and poverty reduction in developing countries (World Bank 2004; Grey and Sadoff 2006). However, although such developments bring many benefits, in the past the poor and vulnerable groups have tended to bear a disproportionate share of the social and environmental costs without gaining a commensurate share of the economic benefits (WCD, 2000).

Recently, the Tana-Beles area has been identified as an economic ‘growth corridor’ by the government of Ethiopia and the World Bank. The intention is to stimulate economic growth and reduce poverty through the development of hydropower and a number of irrigation schemes (MoFED 2006). However, the likely environmental implications of these developments and specifically the impact on lake water-levels have not been fully evaluated. An evaluation, such as this, is crucial because the lake is important to the livelihoods of many people in a number of different ways. The lake and the wetlands in its vicinity are important for domestic water supply, fisheries, grazing and water for livestock, as well as reeds for boat construction. In addition, the lake is important for water transport and as a tourist destination.

This paper describes the use of the Water Evaluation And Planning (WEAP) model to investigate scenarios of future water resource development in the Lake Tana catchment. The model was used to investigate both the reliability of water availability for the planned schemes and their impact on lake water levels and consequently, lake surface area. For each scenario, the implications of maintaining environmental flows downstream of the lake to the Tis Issat Falls (a major tourist attraction) were also ascertained.

The Lake Tana sub-basin

Located at an altitude of 1786 masl, Lake Tana occupies a shallow depression (mean depth 9 m and maximum depth 14 m) in the North Western Ethiopia highlands (Fig. 1). It

is the largest freshwater lake in the country. . The catchment area of the lake at its outlet is 15,321 km²; 20% of this area is covered by the lake.

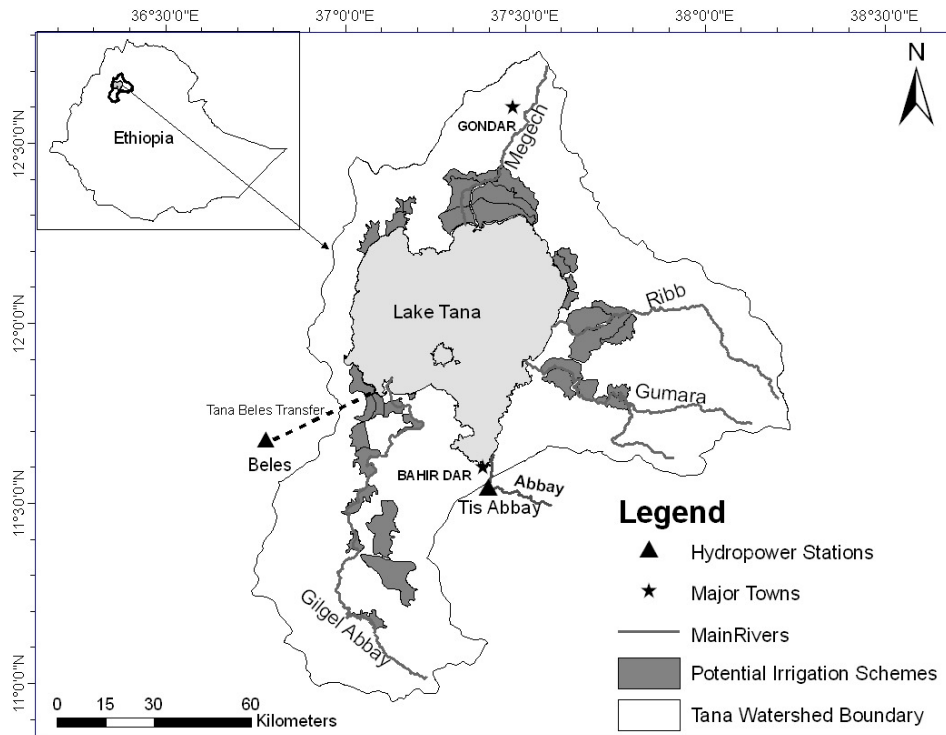

Figure 1: Location map of Lake Tana catchment showing catchment area, major inflowing rivers and planned irrigation and hydropower sites as well as Bahir Dar and Gondar towns (inset map shows location in Ethiopia)

Natural characteristics

The climate of the region is predominantly controlled by the movement of the inter-tropical convergence zone, which results in a single rainy season between June and September. The mean annual rainfall over the catchment is 1,326 mm, with slightly more rain falling in the south and south-east than in the north of the catchment (SMEC 2008). Average annual evaporation over the lake surface is approximately 1,675 mm (SMEC 2008).

Although the lake is fed by more than 40 rivers and streams, 93% of the water comes from just four major rivers: Gilgel Abbay, Ribb, Gumara and Megech (Fig. 1). A recent

study on the lake's hydrology estimated the mean annual inflow to the lake to be $158 \text{ m}^3\text{s}^{-1}$ (i.e. $4,986 \text{ Mm}^3\text{y}^{-1}$) (Table 1). Moreover, the mean annual outflow is estimated to be $119 \text{ m}^3\text{s}^{-1}$ (i.e. $3,753 \text{ Mm}^3\text{y}^{-1}$) (SMEC 2008). Under natural conditions, discharge from the lake is closely linked to rainfall and there is considerable seasonal and inter-annual variability (Kebede et al. 2006). Naturally, the annual water level fluctuations varied between 1785.75 and 1786.36 masl. Analyses of mean annual water levels reveals longer wet and dry cycles of approximately 6-7 years, during which mean annual water-levels rise and fall respectively.

Table 1: Rivers discharging into Lake Tana (Source: SMEC 2008)

	Gilgel Abbay	Ribb	Gumara	Megech	Other	TOTAL
Catchment area (km ²)	1664	1592	1394	462	7,050	12,165
Mean annual flow (Mm ³)	1,810	430	938	189	1619	4,986

The plains surrounding the lake form extensive wetlands during the rainy season. As a result of the high heterogeneity in habitats, the lake and surrounding riparian areas support high biodiversity and are listed in the top 250 lake regions of global importance for biodiversity. About a quarter of the 65 fish species found in the lake are endemic. The lake contains eighteen species of barbus fish (i.e. of the *Cyprinidae* family) and the only extended cyprinid species flock in Africa (Eshete 2003). A three day survey in March 1996 indentified 217 bird species and the lake is estimated to hold a minimum of 20,000 water birds (EVLNHS 1996). In some places, close to the lake shore there is extensive growth of papyrus (*Cyprus papyrus*). The littoral zone (depth 0-4 m) of the lake, which comprises water-logged swamps, the shallow lake margins and the mouths of rivers feeding the lake, is relatively small, covering about 10 % of the total surface area (Eshete 2003).

Current socio-economic situation

The total population in the lake catchment was estimated to be in excess of 3 million in 2007 (CSA 2003). The largest city on the lake shore, Bahir Dar, has a population of over 200,000 and at least 15,000 people are believed to live on the 37 islands in the lake. The

majority of the population lives in rural areas and their livelihoods are mainly dependent on rainfed agriculture. Despite the huge potential, there is very little irrigated agriculture in the basin. Of the estimated 517,500 ha of cultivated land, traditional small-scale irrigation is practiced on less than 500 ha and there is currently no large-scale irrigation.

Though the current fish production of Lake Tana is only about 1,000 tons per year, the potential for production is estimated to be 13,000 tons per annum (Berhanu et al. 2001). However, recent studies show serious declines in fish stocks, most probably due to overexploitation of their spawning grounds (De Gaarf et al. 2006).

The Lake Tana region is endowed with many cultural and natural assets. Key amongst these are approximately 20 monasteries, dating from the 16th and 17th century, located on the lake islands. Also the Tis Issat Falls, one of Africa's greatest waterfalls, is located on the Blue Nile approximately 35 km downstream of the outflow from Lake Tana. Consequently, the area is an important tourist destination. It is estimated that close to 30,000 people (both domestic and foreign) visit the area each year (EPLAUA 2006).

Outflow from Lake Tana is regulated by the Chara Chara weir. This was constructed in 1996 to regulate flow for a hydropower stations located at Tis Abbay, 35km downstream. Prior to construction of the weir, the Tis Abbay I power station (capacity 11.4 MW) relied entirely on diversion of the natural flow of the river immediately upstream of the Tis Issat Falls.

Initially, the Chara Chara weir comprised only two gates, each with a capacity of $70 \text{ m}^3\text{s}^{-1}$. However, to improve regulation an additional five gates, also of capacity $70 \text{ m}^3\text{s}^{-1}$, were added to the weir in 2001. In the same year, a second power station (capacity 73 MW) was constructed at Tis Abbay. Since then the weir has been operated by the Ethiopian Electric and Power Corporation (EEPCO) to maximize power production from both power stations.

The Chara Chara weir regulates water storage in Lake Tana over a 3 m range of water levels from 1784 masl to 1787 masl. The active storage of the lake between these levels is about 9,100 Mm³, which represents approximately 2.4 times the average annual outflow. The regulation for power production has modified the natural lake-level regime, resulting in reduced seasonal but greater inter-annual variability (Fig. 2). The lowest level ever recorded was in June, 2003. This was a drought year in much of Ethiopia and hydropower production was constrained in many places. In an attempt to maintain electricity supplies production at Tis Abay was maximized and as result lake levels declined sharply (Gebre et al. 2007). As a consequence of the low lake levels in 2003, navigation ceased for approximately four months (i.e. when lake levels dropped below 1785 masl, the minimum level at which ships can currently operate), large areas of papyrus reed were destroyed, there was significant encroachment of agriculture on the exposed lake bed and there was a decrease in fisheries production (EPLAUA 2004).

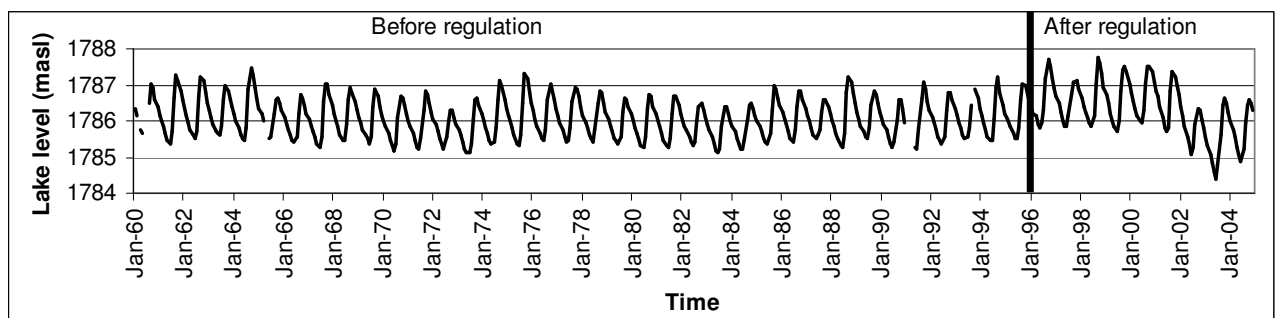

Figure 2: Water level fluctuations of Lake Tana before and after regulation (Source: plotted using data provided by the Ministry of Water Resources)

Planned water resource development

As a result of its significant water resources potential, the Lake Tana catchment is at the centre of Ethiopia’s plans for water resource development and a number of schemes are under development and planned for the future (Fig. 1). Currently, the Tana-Beles project is under construction. This scheme involves the transfer of water from Lake Tana to the Beles River via a 12km long, 7.1 m diameter tunnel (Salini and Mid-day 2006). The aim of the inter-basin transfer is to generate hydropower by exploiting the 311 m elevation difference between the lake and the Beles River. A power station, with generating capacity of 460MW, is being built on the upper Beles River. This will enable far more

electricity to be generated than is currently produced in the Tis Abbay power stations. Approximately 2,985 Mm³ will be diverted through the tunnel each year to generate 2,310 GWh of electricity (SMEC 2008). Both the Tis Abbay power stations will be moth-balled and only used in emergencies.

In addition, a number of irrigation schemes (up to approximately 60,000 ha) are planned on the main rivers flowing into Lake Tana (Table 2). Of these only the Koga irrigation project (6,000 ha) is currently under construction. However, for several of the other schemes detailed feasibility studies have been undertaken and planning is at an advanced stage. It is anticipated that construction of several of the dams and irrigation schemes will commence in the near future.

Table 2: Planned irrigation development in the Lake Tana catchment (source: BCEOM 1998; Mott MacDonald 2004; WWDSE and ICT 2008; WWDSE and TAHAL 2008a, b)

Irrigation scheme	Irrigable area (ha)	Estimated annual gross water demand Mm³⁺	Estimated net water demand (Mm³)⁺	Large dam storage (Mm³)	Stage of development
Gilgel Abbay B	12,852	104 – 142	88 – 121	563	Feasibility studies ongoing
Gumara A	14,000	115	98	59.7	Feasibility studies completed
Ribb	19,925	172 – 220	146 – 187	233.7	Feasibility studies completed
Megech	7,300	63 – 98	54 – 83	181.9	Feasibility studies completed
Koga	6000	62	52	78.5	Under construction
NE Lake Tana	5745	50 – 62	43 -53	Withdrawals from the lake	Pre-feasibility studies completed
NW Lake Tana	6720	54	46	Withdrawals from the lake	Identification
SW Lake Tana	5132	42	36	Withdrawals from the lake	Identification

Note: + demands estimated through crop water modeling and presented in feasibility study reports. Where a range of demands is presented this reflects alternative cropping patterns. Gross minus net demand is water returned to the rivers.

WEAP model application

WEAP was developed by the Stockholm Environment Institute (SEI) in Boston and provides an integrated approach to simulating water systems associated with development (SEI, 2007).

WEAP represents the system in terms of its various supply sources (e.g. rivers, creeks, inter-basin transfer and reservoirs); withdrawal, transmission and wastewater treatment facilities; ecosystem requirements, water demands (i.e., user-defined sectors but typically comprising hydropower, irrigation, domestic supply, etc.). The model essentially performs a mass balance of flow sequentially down a river system, making allowance for abstractions and inflows. The model optimizes water use in the catchment using an iterative Linear Programming algorithm, whose objective is to maximize the water delivered to demand sites, according to a set of user-defined priorities (SEI 2007).

Configuration to the Lake Tana catchment

The modelling of the Lake Tana catchment with WEAP encompassed the major tributaries to the lake, upstream of the proposed dams (i.e. flows that will be affected by the future construction of dams), estimates of flows downstream of the proposed dams and total inflows on other rivers (i.e. flows that will be unaffected by the future development) as well as Lake Tana itself. Lake Tana was simulated as a reservoir (Fig. 3). In addition, because environmental flow requirements downstream of the Chara Chara weir are influenced by flows in the unregulated Andassa River (catchment area 683 km²), which joins the Abbay approximately 17 km downstream of the weir, flows in this river were also incorporated in the model. The model was configured to run on a monthly-time step.

As primary input to WEAP, the inflow series at the planned dam sites were obtained from the relevant feasibility studies for the period 1960-2004. Where necessary, inflow data were augmented using area-weighted estimates from the nearest available flow gauging

station. To simulate the current situation, the Tis Abbay hydropower plants were included as a demand node on the Abbay River, downstream of the lake. To estimate the diversions to the power stations the turbine discharge data from 1964-2006 were obtained from EEPCO.

Each development scenario was run for the 36 years (i.e. 1960-1995). This period was selected both because data are available and it represents a wide range of hydrological variability. Furthermore, it represents years before construction of the Chara Chara weir and so the impact of each development scenario could be compared with the natural water-level regime of the lake.

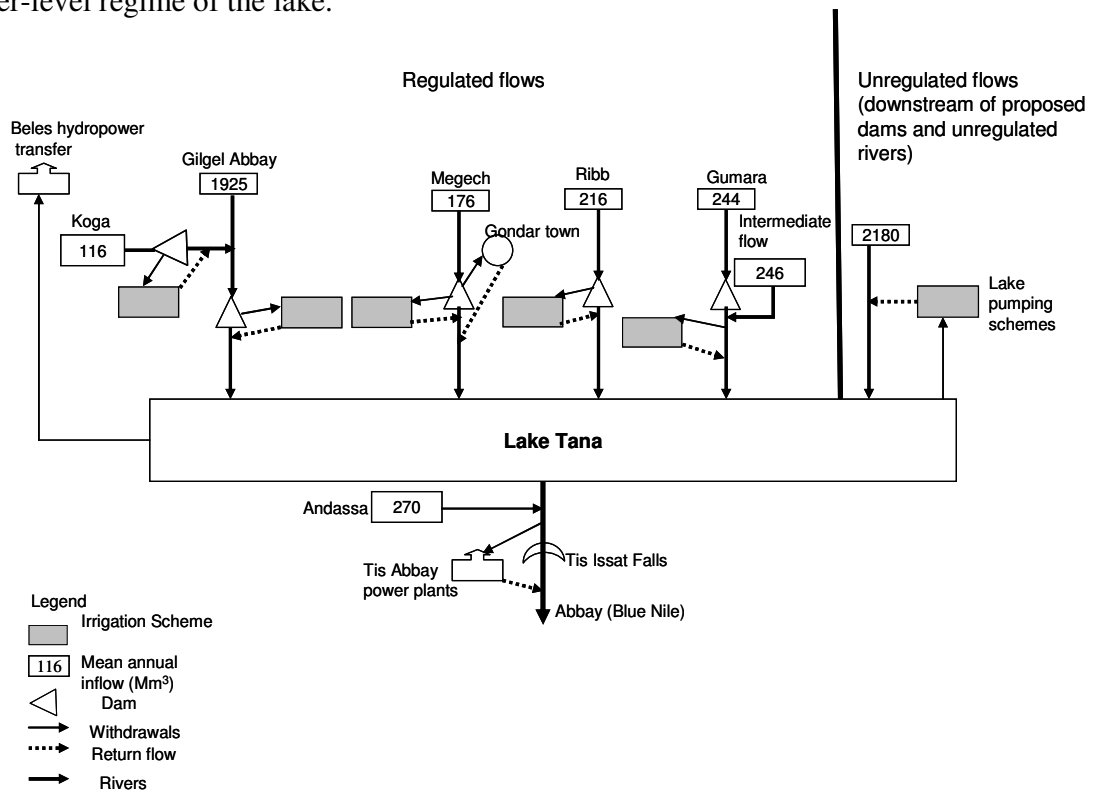

Figure 3: Schematic of existing and planned water demand in the Lake Tana catchment as simulated in WEAP, showing the mean annual flow upstream of the proposed irrigation dams as well as unregulated flows into the lake.

Description of water resource development scenarios

The data underpinning the various scenarios were obtained mainly from the Abbay River Basin Integrated Development Mater Plan and the feasibility studies conducted for each of the proposed schemes. These indicate how the water demand for both irrigation and hydropower is likely to change in the catchment in the future. Four scenarios were developed based on the current stage of scheme development and hence the likelihood of full implementation (Table 3). Water demands for the irrigation schemes were entered into WEAP as monthly time series of net demands (i.e. gross demand minus the estimated return flows).

For the proposed new dams no operating rule curves are currently available. Consequently, no operating rules were incorporated within the WEAP model. This meant that the reservoirs were not drawn down to attenuate wet season floods and no restrictions were applied on abstractions as the reservoirs emptied. The one exception was Lake Tana itself where the operating rule was derived from the calibration process. In this case parameters were set using the pattern of operation in recent years. Thus, restrictions on draw-down were applied to reduce abstractions as lake levels dropped below 1786 masl and to ensure levels did not drop lower than the current physical minimum of 1784 masl.

Since it provides the highest economic returns hydropower production was designated a higher priority than irrigation. With the exception of the water demand for the city of Gondar, which in future will be abstracted from the Megech River, the water demand for domestic, municipal and industrial use, were not considered. This is because their impact on the water resources of the lake, both now and in the future, is insignificant (SMEC 2008).

For each scenario the WEAP model was used to predict: i) the impacts on both lake water-levels and lake area for each month over the 36 years simulated and ii) the unmet demand for hydropower and each irrigation scheme.

Table 3: Summary of development scenarios (Source: BCEOM 1998; EEPCO database and SMEC 2008)

Scenario	Hydropower developed	Irrigation schemes developed	Total mean annual water demand (Mm ³) ⁺
Baseline (BS)	Tis Abbay I and II	-	3,469
Ongoing development (ODS)	Tana Beles transfer	Koga	3,047
Likely future development (LDS)	Tana Beles transfer	Koga, Megech, Ribb, Gumara and Gilgel Abbay	3,621
Full potential development (FDS)	Tana Beles transfer	Koga, Megech, Ribb, Gumara, Gilgel Abbay and 3 schemes pumping directly from the lake	3,768

Note: + water demand has been calculated using the highest crop water estimates for each of the irrigation schemes.

An environmental impact assessment was conducted for the Tana Beles transfer scheme. To maintain the ecosystem of the upper reaches of the Abbay River this recommends an average annual release from Chara Chara of $17 \text{ m}^3\text{s}^{-1}$ (536 Mm^3) with an absolute minimum of $10 \text{ m}^3\text{s}^{-1}$ (Salini and Mid-day 2006). This environmental flow requirement, hereafter referred to as the minimum maintenance flow (MMF), was included in all the scenarios. Moreover, the proposed minimum instream flows downstream of each of the proposed dams (as identified in the feasibility studies) were also included in each scenario.

Recently, a more detailed evaluation of the environmental flow requirements needed to maintain the ecosystem of the Tis Issat Falls has been conducted (McCartney et al. 2008). This study allowed for the natural seasonal and inter-annual variability of flow and estimated environmental flow requirements on a monthly time-step for the period 1960-2004. The study found that to maintain the basic ecological functioning of the reach containing the Falls, variable flows are necessary, with an average annual allocation of 864 Mm^3 (i.e. 64% more than previously estimated) (McCartney et al. 2008). To ascertain the effect of the variable environmental flow (VEF) requirement, over and above the minimum maintenance flow, each scenario was run again with the variable environmental flow included. All environmental flows were given higher priority than the hydropower production.

Results

Figure 4 presents a comparison of the time series of simulated lake levels for all scenarios with the natural condition, both with the downstream MMF and the VEF included.

4a)

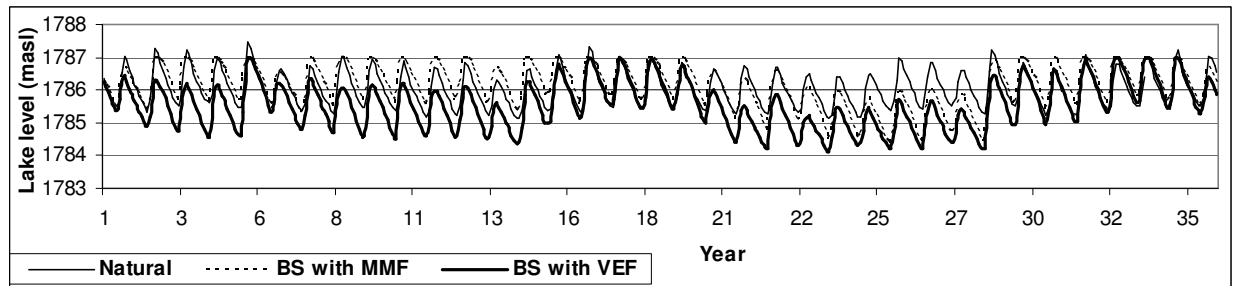

4b)

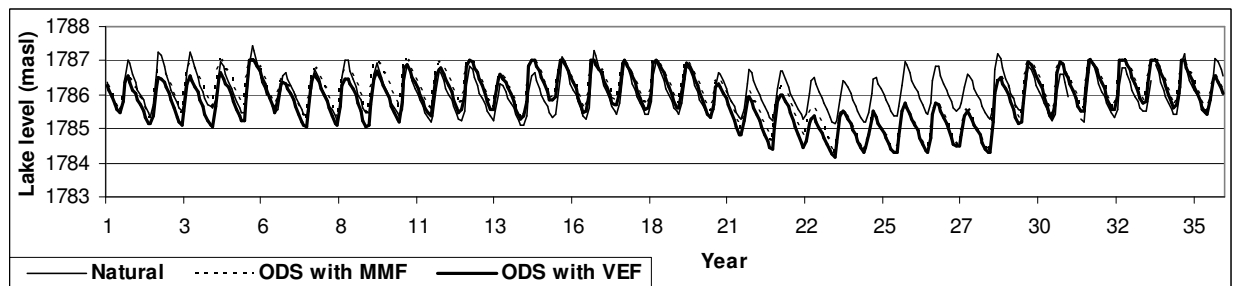

4c)

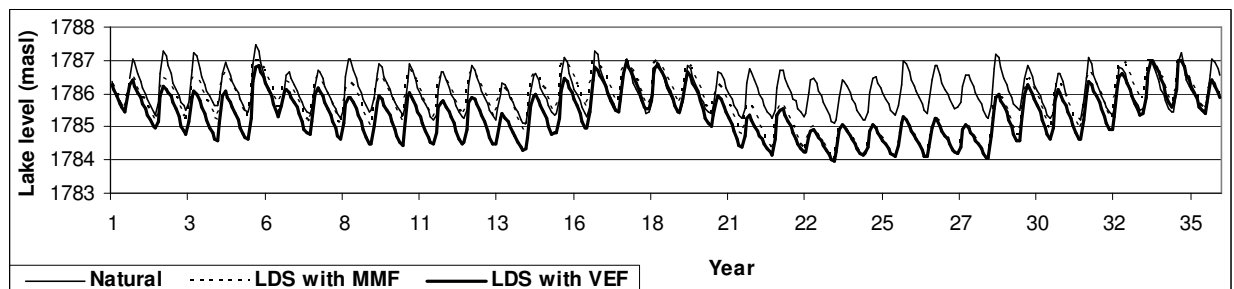

4d)

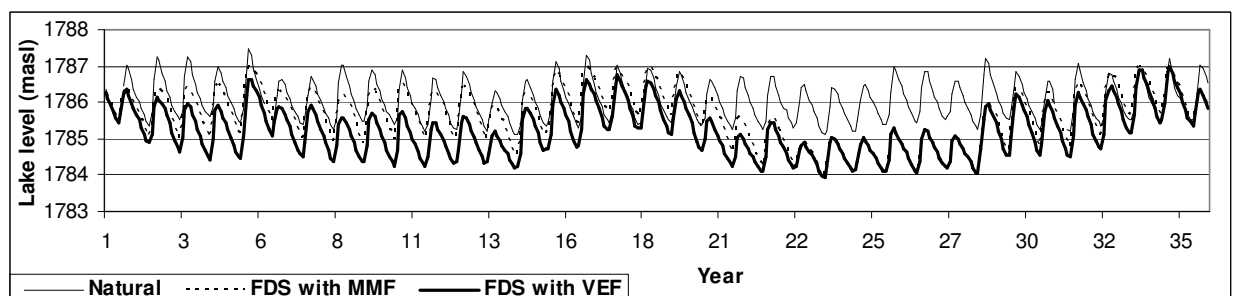

Figure 4: Comparison of simulated and natural (observed) lake levels over 36 years with, for each scenario, the minimum maintenance flow (MMF) and the variable environmental flows (VEF). Scenarios are: 4a) baseline scenario (BS), 4b) ongoing development scenario (ODS), 4c) likely future development scenario (LDS) and 4d) full potential development scenario (FDS).

Table 4 summarizes the results of each scenario both with the MMF the VEF. The results indicate the decline in mean annual lake levels, and consequently lake area, as the water resource development in the catchment increases. This is manifested particularly by the increasing periods of time when lake levels are below 1785 masl, the minimum required for ships to navigate on the lake. Even without the VEF releases, in the full potential development scenario, water-levels exceed 1785 masl just 78.0% of the time (Table 4) and in some years hardly exceed this level in any months (Fig. 4d). This would have a very significant impact on shipping in the lake.

As would be expected, the greatest impact of the water resource development occurs during dry cycles in particular years 8-14 and most significantly from years 20- 28 of the simulation. During these periods, even without variable environmental flow releases, lake water levels are, depending on the development scenario, up to 0.82 m and 1.76 m lower than natural levels in the dry and wet season, respectively (Fig. 4).

The VEF requirements exacerbate the drop in lake water-levels in all scenarios. For the full development scenario the water level exceeds 1785 masl just 60% of the time and the mean lake area is reduced from 3,080 km² to 3,023 km² (Table 4). Furthermore, the amount of power produced and the amount of water diverted to irrigation are reduced by between 1% and 3% for hydropower and 2% to 5% for irrigation, depending on the scenario.

Table 4: Summary of simulation results for each scenario with minimum maintenance flow and variable environmental flows

Scenario	Minimum Maintenance Flow					Variable Environmental Flow				
	Mean water levels (masl)	Mean lake area (km ²)	Mean power generated GWhy ⁻¹	Mean irrigation water supplied Mm ³ y ⁻¹	% time that mean water level exceeds 1785 masl ⁺	Mean water levels(masl)	Mean lake area (km ²)	Mean power generated GWhy ⁻¹	Mean irrigation water supplied Mm ³ y ⁻¹	% time mean water level exceeds 1785 masl
Natural	1786.05	3080	15.7*	0.0	100.0	1786.05	3080	15.7*	0.0	100.0
BS	1786.11 ⁺⁺	3084 ⁺⁺	356.7	0.0	93.5	1785.55	3045	332.8	0.0	75.2
ODS	1786.01	3077	2247.0	55.2	90.1	1785.86	3067	2225.1	53.9	88.7
LDS	1785.72	3057	2207.1	548.3	81.0	1785.39	3034	2177.8	537.0	66.4
FDS	1785.61	3049	2197.6	676.9	78.0	1785.24	3023	2134.2	644.2	59.7

Note: + 1785 masl is the minimum level required for shipping

* hydropower produced by Tis Abay I power station by diverting unregulated flow

++ increase in average lake water level and lake area occurred as a consequence of regulation which slightly increased dry season water level and area

Table 5 presents the average annual shortfall (as a percentage of the annual demand) for both irrigation and hydropower in each of the scenarios with both the MMF and the VEF. As would be expected, shortfalls occur mainly in dry years. In the model hydropower was given higher priority than irrigation, so shortfalls in hydropower production are less than in irrigation. Nevertheless, shortfalls in hydropower significantly increase as the irrigation development in the basin increases. Hence, even without allowing for the VEF average annual hydropower production declines from 2,247.0 GWh to 2,207.1 GWh and 2197.1 GWh if all the planned and all the possible irrigation schemes are developed respectively (Table 4). If the VEF is included unmet hydropower and irrigation demands both increase significantly (Table 5).

Table 5: Unmet demands for irrigation and hydropower in each scenario with minimum maintenance flow and variable environmental flows

Scenarios	Irrigation				Hydropower			
	Minimum Maintenance Flow		Variable Environmental Flows		Minimum Maintenance Flow		Variable Environmental Flow	
	Unmet demand %	Maximum unmet demand % (year)	Unmet demand %	Maximum unmet demand % (year)	Unmet demand %	Maximum unmet demand % (year)	Unmet demand %	Maximum unmet demand % (year)
BS	0.0	0.0	0.0	0.0	0.6	8.1(29)	7.3	41.4(24)
ODS	10.4	83.9(25)	12.5	90.2(25)	2.6	22.4(26)	3.5	33.3(24)
LDS	13.8	70.9(26)	15.6	72.9(24)	4.3	34.9(24)	5.6	36.5(24)
FDS	13.5	71.0(26)	17.7	72.6(24)	4.7	34.9(24)	7.5	38.8(24)

Discussion and conclusion

The analyses conducted in this study quantify some of the possible impacts arising from future development of the water resources of the Lake Tana catchment. The modeling results indicate that the water level of Lake Tana will be influenced by upstream development on the inflowing rivers, the diversion to the Beles catchment and the release of flow downstream of the Chara Chara weir. As would be expected, the effects on lake levels will be more pronounced during dry periods. In the past, the water level of the lake was controlled more by rainfall variation than by human activities (Kebede et al. 2006).

In future, as a result of infrastructure development, anthropogenic activities will be the major control.

A recent assessment of Lake Tana and its associated wetlands identified a number of human induced ecological threats, including siltation, over fishing, recession agriculture and water level disturbance due to water withdrawals (EPLAUA 2006). In the absence of careful management all these threats are likely to be aggravated by the planned future development.

Approximately $3,600 \text{ Mm}^3\text{y}^{-1}$ of water will be diverted for hydropower and irrigation schemes if the full development scenario in the Lake Tana catchment is implemented. Consequently, the mean annual water level will be lowered by 0.44 m and there will be prolonged periods, of several years, during which water levels will be much lower than they would be naturally. Due to this the average surface area of the lake will decrease by 30 km^2 (i.e. 3,000 ha). In some years it will be reduced by as much as 81 km^2 (81,000 ha) during the dry season. This is likely to have significant impacts on the ecology of the lake, particularly the littoral zone and in the wetlands around the shoreline. The desiccation of currently wet areas will certainly cause the loss of aquatic vegetation, including papyrus reeds. As a result the breeding habitat for aquatic fauna, including fish is likely to be reduced. This could have a significant impact on the productivity of the lake fisheries. In Lake Victoria declining water levels in recent years have altered fish breeding grounds and *refugia* and this is believed to have resulted in a reduction in fish populations (EAC 2006).

As well as the implications for the lake itself, the environmental impacts of the dams on the rivers feeding into Lake Tana need to be carefully assessed. In particular the likely impacts on migratory fish like the *Barbus sp.*, which is believed to move up to 80km upstream in the Ribb River (SMEC 2008) and is an important food source for local communities, needs to be determined. Further consideration also needs to be given to the likely impacts on wetlands and sedimentation in the vicinity of the river mouths.

In 2003, farmers extended crop production onto about 562 ha of Lake Tana bed following the lower levels (EPLAUA 2004). This indicates that lower water levels will almost certainly result in people moving both cultivation and grazing onto the dried lake bed. This would exacerbate adverse impacts on near-shore vegetation and could greatly increase sedimentation in the lake. Moreover, during periods of extended drawdown it is possible that people will also move their homes onto the waterless lake bed. In such a situation rapid rises in lake levels could be disastrous, threatening both lives and livelihoods.

Lower water-levels, particularly in the dry season, will have a negative impact not only on the ecology of the lake but on navigation. As a consequence of lower water levels in 2003, Lake Tana Transport Enterprise lost about 4 million Ethiopian birr (i.e. approximately US\$ 400,000) because the ships could not sail (Dagne, personal communication). Due to the fact that the livelihoods of many people are dependent on shipping, strategies need to be developed to mitigate these impacts. These could include modification of ports as well as the ships themselves to enable them to operate at lower water-levels.

The WEAP simulations show the water availability for both irrigation and hydropower in each scenario. The results indicate that as demands rise in future, shortfalls in water supply will increase during dry periods. Very careful consideration needs to be given to the economic implications of reduced reliability of supply particularly for hydropower production in the Beles, resulting from increasing irrigation in the Lake Tana catchment.

In this study consideration was given only to the possible changes arising from future water resource development in the Lake Tana catchment. However, the water resources of the Lake Tana catchment are highly vulnerable to changes in rainfall and temperature. In a study of possible impacts of climate change on the hydrology of the Gilgel Abbay River, it was estimated that by 2080 mean annual runoff into the lake could be reduced by approximately 3% with much greater reduction in some years (Shaka 2008). However, this estimate makes no allowance for increased irrigation demand as a consequence of

lower rainfall and higher temperatures. It is also probable that climate change will affect the temporal distribution of runoff (Deksyos and Abebe, 2006; Shaka, 2008) and this could also affect both water availability and irrigation demand. Hence, much more detailed studies of the possible impacts of climate change, including economic and livelihood implications, need to be undertaken.

The simulation results indicate that the allowance for variable environmental flows over the Tis Issat Falls reduces the availability of water for both hydropower and irrigation and causes increased drawdown of the lake. In the full development scenario the variable environmental flows reduce the average lake levels by an additional 0.37 m and the average surface area of the lake by an additional 26 km² (i.e. 2,600 ha). This is over and above the reductions resulting from the MMF and will almost certainly further exacerbate the adverse environmental and social impacts arising from drawdown of the lake. Therefore, a potential trade-off exists between the lake ecosystem and the ecosystem of the upper Abbay River and the Falls. Since the livelihoods and well being of many people are directly dependent on the ecological character of both ecosystems, very careful consideration needs to be given to determining how the water is best utilized. This requires much more detailed analyses of both the environmental and social consequences of water allocation patterns.

Acknowledgements

We are grateful to the CGIAR Challenge Program on Water and Food, project number 36: 'Improved planning of large dam operation' and Addis Ababa University, Science Faculty for research grant to Tadesse Alemayehu. The authors are also grateful to the Federal Ministry of Water Resources, the Ethiopian Electric Power Corporation and the National Meteorological Agency for the provision of data.

References

BCEOM (1998). "Abbay river basin integrated development master plan, section II, volume V-water resources development, part 1- irrigation and drainage." Ministry of Water Resources, Addis Ababa, Ethiopia.

Bellier, C., Howard, H., Kennedy, R. and Donkin. (1997). "Tis Abbay II hydroelectric project, environmental impact assessment." Federal Democratic Republic of Ethiopia, Ministry of Water Resources, Addis Ababa, Ethiopia.

Berhanu, T., Ralphe, L. and Girma, Z. (2001). "Development initiatives and challenges for sustainable resource management and livelihood in Lake Tana region of Northern Ethiopia." Proceeding of wetland awareness creation and activity identification workshop in Amhara Regional State, January 23rd, 2001, Bahir Dar, Ethiopia.

Central Statistics Authority (CSA) (2003). "Ethiopian agricultural sample enumeration, 2001/2002 results for Amhara region, statistical reports on area and production of crops, part II B". Central Statistics Agency, Addis Ababa, Ethiopia.

De Graaf, M., van Zwieten, P., Machiels, M., Endale, L., Tesfaye, W., Eshete, D., Sibbing, F. (2006). "Vulnerability to a small-scale commercial fishery of Lake Tana's (Ethiopia) endemic labeobarbus compared with African Catfish and Nile tilapia: An example of recruitment-Over fishing?" Fisheries Research, 82 (2006) 304–318.

Dekseyos, T. and Abebe, T., 2006. Assessing the impact of climate change on the water resources of the Lake Tana sub-basin using the Watbal model, CEEPA Discussion Paper No.30, CEEPA, University of Pretoria.

East African Community (EAC) (2006). "Special report on the declining of water levels of lake Victoria". Lake Victoria Basin Commission, Arusha, Tanzania.

Environmental Protection Land Administration and Use Authority (EPLAUA) (2004). "Water level reduction of Lake Tana and its environmental impacts". Bahir Dar, Ethiopia.

Environmental Protection Land Administration and Use Authority (EPLAUA) (2006). "Ecological significances, threats and management options of Lake Tana-associated wetlands." Bahir Dar, Ethiopia.

Eshete, D. (2003). "The small barbs of Lake Tana". Doctoral thesis, Experimental Zoology Group, Wageningen University, The Netherlands.

Ethiopia Wild Life and Natural History Society (EWLNHS) (1996). "Important bird areas of Ethiopia, first inventory." Addis Ababa, pp 103-107.

Gebre, A., Getachew, D. and McCartney, M.P. (2007). "Chara Chara stakeholder survey." Project report for CPWF project 36: Improved planning of large dam operation:

using decision support systems to optimize livelihood benefits, safeguard health and protect the environment. International Water Management Institute (IWMI).

Grey, D. and Sadoff, C. (2006). "Water for growth and development." A theme document of the the 4th World Water Forum. Mexico City, Mexico. 56 pp.

Kebede, S., Travi, Y., Alemayehu, T. and Marc, V. (2006). "Water balance of Lake Tana and its sensitivity to fluctuations in rainfall, Blue Nile Basin, Ethiopia." *Journal of Hydrology* 316, 233-247.

McCartney, M.P, Abeyu, S. and Yilma, S. (2008). "Estimating environmental flow requirements downstream of the Chara Chara weir on the Blue Nile River." Paper presented at Hydrology and Ecology of the Nile River Basin under extreme conditions, June 16-19, 2008, Addis Ababa, Ethiopia.

McCartney, M.P. (2007)." Decision support systems for large dam planning and operation in Africa." International Water Management Institute. 47 p. (IWMI Working Paper 119), Sri Lanka, Colombo.

Ministry of Finance and Economic Development (MoFED) (2006). "A plan for accelerated and sustained development to end poverty (PASDEP), (2005/06-2009/10), volume I." Addis Ababa, Ethiopia.

Mott MacDonald (2004). "Koga irrigation project interim report." Ministry of Water Resource, Addis Ababa, Ethiopia.

Salini and Mid-day (2006). "Environmental impact assessment for Beles multipurpose project." Ethiopian Electric and Power Corporation, Addis Ababa, Ethiopia.

Shaka, A. (2008). "Assessment of climate change impacts on the hydrology of the Gilgel Abbay catchment in the Lake Tana Basin, Ethiopia." MSc thesis, ITC, Netherlands 72 pp. SMEC (2008). "Hydrological Study of the Tana-Beles sub-basins, main report." Ministry of Water Resource, Addis Ababa, Ethiopia.

Stockholm Environment Institute (SEI) (2007). "WEAP: Water Evaluation and Planning system – user guide." Stockholm Environment Institute, Boston, USA.

Water Works Design and Supervision Enterprise (WWDSE) and ICT (2008). "Gumara irrigation project, final feasibility study report, volume III: water resources (a), annexure-7: meteorological and hydrological studies." Addis Ababa, Ethiopia.

Water Works Design and Supervision Enterprise (WWDSE) and TAHAL (2008a). "Lake Tana sub-basin four dams project, final feasibility report for Ribb irrigation project, volume III: hydrological report." Addis Ababa, Ethiopia.

Water Works Design and Supervision Enterprise (WWDSE) and TAHAL (2008b). “Lake Tana sub-basin four dams project, final feasibility report for Megech irrigation project, volume III: hydrological report.” Addis Ababa, Ethiopia.

World Bank (2004). “The water resources sector strategy: an overview.” The World Bank, Washington D.C.

World Commission on Dams (WCD) (2000). “Dams and Development: a new framework for decision-making.” The report of the World Commission on Dams. Earthscan Publications, Thanet Press. London, UK.